

PRODUCT INFORMATION SHEET

1064nm Polarization Maintaining Fiber Collimator (PMC Series)

The 1064nm PM Fiber Collimator is the basic element for in-line PM fiber optics components, such as PM isolator and PM FWDM. It has high extinction ratio, low insertion and high return loss. The unique processing and high quality AR coating also enable this collimator to handle high power.

Specifications

Parameters	Unit	Values
Center Wavelength	nm	1064 or Specify
Operating Wavelength Range	nm	± 30
Working Distance	mm	5 or Specify
Typ. Insertion Loss @ 5mm	dB	0.25
Max. Insertion Loss @ 5mm	dB	0.3
Typ. Extinction Ratio	dB	25
Min. Extinction Ratio	dB	22
Min. Return Loss	dB	60
Tensile Load	N	5
Fiber Type		PM 980 Panda Fiber or Specify
Operating Temperature	°C	-5 to +70
Storage Temperature	°C	-40 to +85

Above specifications are for device without connector. PM fiber & connector key are aligned to the slow axis.

*For devices with connectors, IL will be 0.3dB higher, RL will be 5dB lower, and ER will be 2dB lower.

Package Dimensions

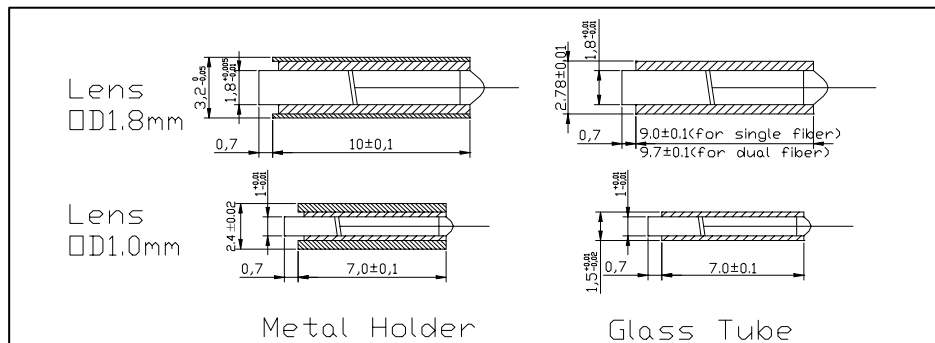
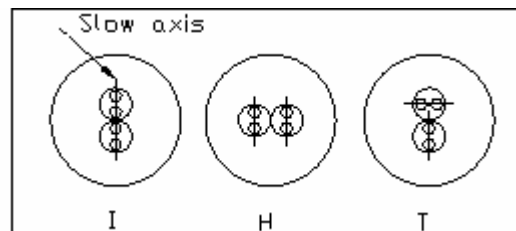

Figure for Slow axis orientation



Ordering Information

PMC-①-②-③-④-⑤-⑥-⑦-⑧-⑨

- | | | | | |
|---|--|---|--|---|
| ① Lens Diameter
1 - 1.8mm
2 - 1.0mm(for single fiber only)
S - Specify | ② Pigtail Type
1 - Single fiber pigtail
2 - Dual fiber pigtail
S - Specify | ③ Center Wavelength
06 - 1064nm
SS - Specify | ④ Package Type
1 - Metal holder
2 - Glass tube | ⑤ Working Distance
1 - 5 mm
S - Specify |
| ⑥ Connector Type
N - None
S - Specify | ⑦ Fiber Type
B - 250um bare fiber
L - 900um loose tube
T - 900um tight buffer fiber(only for single fiber)
S - Specify | ⑧ Slow Axis orientation
O - For single fiber collimator
I, H, T - For Dual fiber collimator(refer to figure)
S - Specify | ⑨ Fiber Length
C - 1.5m
S - Specify | |